

HOT-SPARK™ IGNITION PRODUCTS

Installing a Hot-Spark Electronic Ignition Kit in a Ford, FoMoCo, Motorcraft, Autolite vacuum advance distributor

NOTE:

Reversing the red and black ignition wires will destroy the ignition module and void the warranty.

The Hot-Spark module's red wire connects to positive (+) terminal. The black wire connects to the negative (-) terminal. Remove the condenser and its wire from vehicle. Connect any other wires to the coil in their original positions. This module requires a 12V negative ground electrical system.

Make sure that the ignition wires have plenty of slack inside the distributor and are not rubbing on any moving parts. If you need to extend the length of the ignition wires, use 18- or 20-gauge (AWG) wire. Crimp tightly or solder all connections.

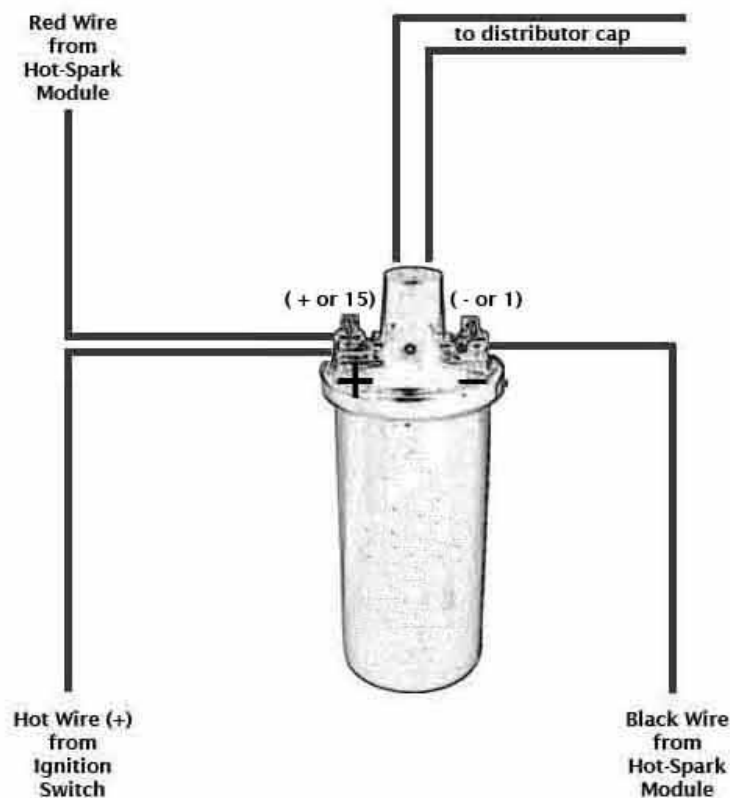

Note: Always make sure that engine oil level is on the full mark before revving the engine

Prior to install: After removal of the breaker points, clean the distributor's breaker points plate thoroughly, so that the ignition module's base plate makes good thermal contact with the distributor.

Coil to use: Stock Bosch coil or **HS15HEC** high-energy coil OK. Coil should have 1.5 Ohms or more primary resistance. To measure primary resistance: Label and remove all wires to coil. Using a common digital multimeter in the 200 Ω mode, measure between coil's + and - terminals. Allow a few seconds for the reading to settle downward, until it stabilizes. Subtract about 0.3 Ohms from the reading to compensate for multimeter's inherent resistance.

For best performance, the coil should also have a minimum of 7,000 Ohms secondary resistance (measured from coil's + or - terminal to center high tension terminal, in the 20K Ω mode of the Ohmmeter). Note: Do not use a low-resistance coil, such as the MSD or Accel coil - they don't have enough primary resistance for this application. **Using a coil with too little primary resistance can cause the ignition module to overheat and fail, thus voiding the warranty.**

Test Maximum Charging System Voltage: If the charging system voltage, measured at the coil's positive terminal, is more than 14.2 volts at 2,500+ RPM, the voltage regulator likely needs replacing. Too much voltage can damage the ignition module and other electronic components.

Air Gap between Magnet Sleeve and Ignition Sensor: The air gap should be approximately 0.8 mm (.030 in.), although exact gap is not critical. There should be sufficient gap to prevent the magnet sleeve from rubbing against the Hot-Spark sensor. If there's not a wide enough gap between the magnet sleeve and the ignition sensor, you can on some kits adjust the distance. On the kits that do not have this option, you can hold ignition base plate towards the position it needs to be moved while tightening the set screw. If this is not enough you can try the following: With the ignition module fastened to the distributor's breaker plate, bend the top, red part of the ignition module away from the magnet sleeve slightly, to widen the gap a little. Don't pry against the plastic magnet sleeve - it may break. Note: when making adjustments: do not over-tighten these nuts - apply no more than 5 ft. lbs. of torque! Use a nut driver, not a socket wrench.

Ignition Timing: Set the ignition timing, with a stroboscopic light, to the distributor's factory specification. The difference in distributor position with points vs. electronic ignition can be as much as 30 degrees or so clockwise or counterclockwise, so you'll definitely have to reset the timing.



Example of a Hot-Spark kit in a Ford vacuum-advance distributor

1. Turn off the ignition switch and/or remove the ground strap from the battery. Though not absolutely necessary, it is probably easiest overall to remove the distributor from the car before installing the Hot-Spark module. If the contacts in the inside of the distributor cap are worn or damaged, replace the distributor cap. Replace the rotor if it's worn.
2. Remove distributor cap, leaving the plug wires in place, unless replacing the distributor cap as well.
3. Remove points, condenser and the condenser's wire from the vehicle. If there is a wire that used to go to the condenser, tape it off, as it will no longer be used. Because the Hot-Spark kit does not modify the distributor, the points and condenser can be reinstalled at a later time.
4. Clean any grease or dirt thoroughly from the distributor's points cam and the breaker points plate.
5. Insert the Hot-Spark module's wires, one at a time, from the inside of the distributor out, through the hole in the side of the distributor. You can use a narrow, flat-bladed screwdriver to gently push the edges of the grommet from the inside of the distributor. Gently pull and rock, up-and-down and side-to-side, the rubber grommet, halfway through the hole, until it seats.
6. Apply a *very* thin coat of the included thermal transfer grease to the bottom of the ignition base plate. Place the Hot-Spark module's bottom plate onto the distributor's breaker plate. The screw holes used to secure the points should line up with the ignition module holes. The Hot-Spark module's base plate should lie flat and snug on the distributor's breaker plate. Insert the screw and tighten.
7. Press the magnet sleeve down on the rotor shaft. Next install the rotor on top of the magnet sleeve. The rotor should slide all the way down and lock into place, so that it cannot turn independently of the distributor shaft. If you can still turn the rotor independently of the distributor shaft, the magnet sleeve is not seated all the way down. Be sure that the indentations inside the magnet sleeve line up with the lobes of the distributor cam - turn the magnet sleeve on the distributor shaft until you can feel it line up.
8. Check to see if the vacuum advance is working properly by sucking on or applying vacuum to the vacuum canister port. The breaker plate should move smoothly and freely.
9. Adjust the two Hot-Spark ignition wires so that they have plenty of slack inside the distributor and they're not rubbing on any moving parts.
10. Install the distributor cap and reinstall the distributor. Be sure that the anti-chatter spring is in place in the distributor drive gear in the bottom of the distributor shaft hole.
11. The Hot-Spark module's red wire connects to positive (+) terminal. The black wire connects to negative (-) terminal. DO NOT reverse the polarity of these wires or the ignition module will be destroyed.
12. Check all wire connections, including the two Hot-Spark wires and the spark plug and coil high-tension wires. If you need to extend the length of the wires, use 18- or 20-gauge wire. We recommend soldering all splices and connections, if you can, or crimp all connections tightly. Make doubly sure that all wires are connected to the proper terminals, etc. before reconnecting the battery or turning the ignition switch to the ON position. Make sure that all connectors are snug. Reconnect the battery.
13. You can set the timing statically to about 0° (TDC) at first, so that the engine will start. You may need to turn the distributor, a little at a time, right or left, to enable the engine to start and remain running. Time the engine with a stroboscopic light in the normal manner. This will probably be the last time you have to set the timing for a long time, so it's worth it to spend the extra time and effort to set the timing absolutely spot-on accurately. An engine with its timing set to perfection will start with the slightest bump of the starter and purr like a kitten at idle – something to make you feel good every time you start the engine.

Cleaning, lubricating and checking:

Lubricating: You likely won't have the distributor out of the engine again for some time. So now is a good time to lubricate under the vacuum advance plate, the distributor shaft and its bushing and the swinging centrifugal advance weights in the bottom of the distributor. You can access the centrifugal advance weights easily by removing the curved plug on the outside of the distributor, near the bottom. A somewhat sharp, flat-bladed putty knife is handy for prying off this plug. A small amount of heavy oil, such as 90W hypoid, synthetic heavy transmission oil or heavy motor oil works well for lubricating the distributor. Don't use a thin solvent, such as WD-40, for lubrication, as its lubricating qualities won't last for long. Apply a few drops of oil to the felt wick under the rotor. Clean up any excess oil or grease.

Vacuum canister check: If your engine uses a vacuum-advance distributor, test the vacuum canister by sucking hard on its vacuum port. The vacuum advance plate, under the points, should move counterclockwise and clockwise noticeably and freely when you do this repeatedly. If you suck and then cover the vacuum port with your tongue, the vacuum advance plate should stay in the same position until you lift your tongue. If it drifts back before you lift your tongue, the diaphragm is leaking and it won't advance the timing properly. In that case you need to replace the vacuum canister or the entire distributor. If the distributor is dirty and covered with gunk inside and out, you may need to soak it in a solvent such as naphtha or kerosene (don't allow solvent to leak into the vacuum canister - remove the vacuum canister first). After soaking and scrubbing with a stiff nylon brush, rinse thoroughly with clean solvent, dry with compressed air or allow to air-dry and lubricate the shaft, bushing, advance weights and breaker advance plate. Wipe up excess grease and oil. If the vacuum advance plate still doesn't move freely, you may need to replace the vacuum canister or replace the distributor.

Testing the Coil's Spark: Begin with a fully charged battery. Disconnect the high-tension cable from the center terminal of the distributor cap. Hold it about 10 mm (3/8") from the engine crankcase. (Be sure that you're very well insulated from the end of the high-tension cable or many thousands of volts could course through your body!) Have a helper crank the engine while you watch the spark produced. A weak coil will produce an anemic yellowish or orange spark; it might fire only when the cable is moved close to the crankcase or it won't fire at all. A healthy coil will produce a bright bluish-white spark with a loud, distinct CRACK! sound. If your coil doesn't produce a strong, whitish-bluish spark, you should replace it.

Distributor Cap and Rotor: Stock rotors and distributor caps work fine with the Hot-Spark module. A worn, corroded or scored distributor cap and/or rotor is often the cause of the timing jumping around erratically at idle. With the Hot-Spark electronic ignition installed in place of points, several times as much voltage surges through the rotor to the distributor cap terminal contacts. While the rotor and distributor cap may have functioned alright with points, the increased strain of double the voltage may be too much for the old, worn rotor and distributor cap. We recommend installing a new distributor cap and rotor when converting from points to electronic ignition.

Spark Plug Gap: With the Hot-Spark ignition kit, the stock spark plug gap specification is fine. For racing purposes, you can increase the spark plug gap by about .005 inches, or .12 mm. Be aware that changing the spark plug gap can affect the timing - you should recheck the ignition timing if you change the spark plug gap.

Using Hot-Spark Ignition with MSD Blaster:

Refer to this diagram to use the Hot-Spark Ignition with the MSD (Multiple Spark Discharge) Blaster:

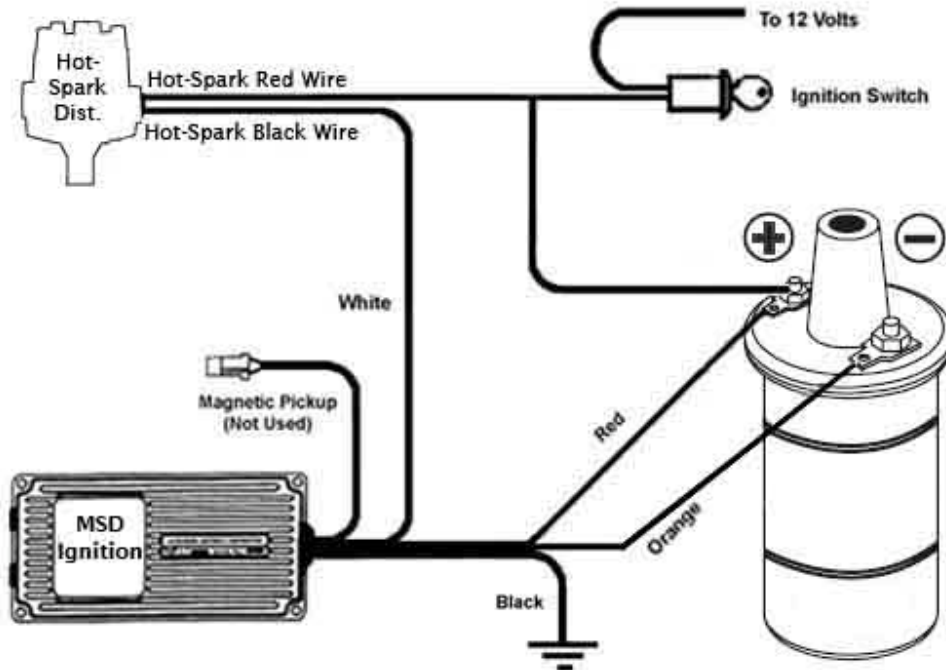

Hot-Spark Ignition and MSD 6 Series Wiring Diagram:

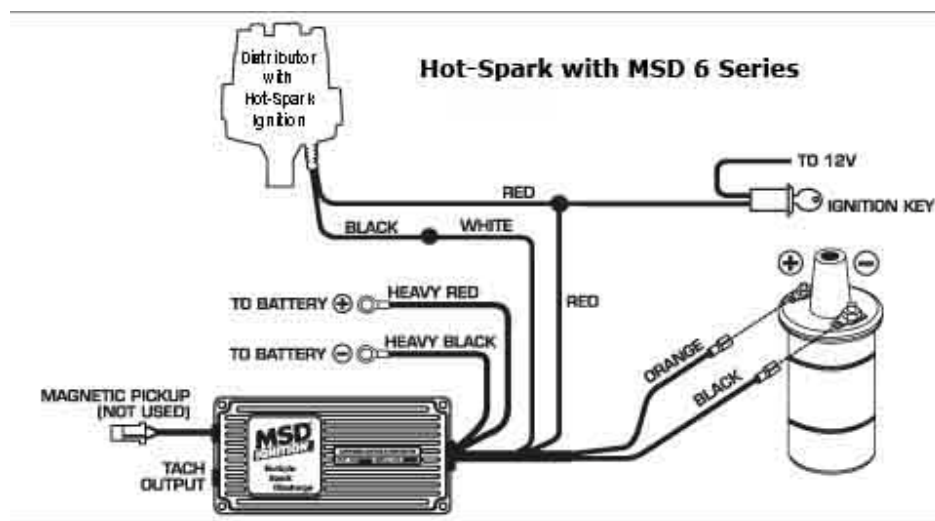

Limited Warranty: Hot-Spark Ignition Products warrants its electronic ignition conversion kits to be free from defects in material and workmanship under normal use and if properly installed for a period of three years from date of purchase. If found to be defective as mentioned above, it will be replaced or repaired if returned prepaid along with proof of date of purchase. Warranty shall be null and void if it is determined that said electronic ignition conversion kit has been connected improperly, if it is used with an ignition coil which has insufficient resistance in its primary circuit or if the polarity of the electrical wiring of the ignition kit has been reversed.

This shall constitute the sole remedy of the purchaser and the sole liability of Hot-Spark Ignition Products. To the extent permitted by law, the foregoing is exclusive and in lieu of all other warranties or representations whether expressed or implied, including any implied warranty of merchantability or fitness. In no event shall Hot-Spark Ignition Products be liable for special or consequential damages.

www.Hot-Spark.eu

© 2007 Hot-Spark™ Ignition Products